

Product Data and Application Sheet

Product Name: Service Fuse

Product Code: SF80F, SF80

Description: 100 Amp Fuse Holder with 80 Amp Fuse Back and Front Wired

Features:

- 100 Amp Fuse Holder
- 80 Amp Fuse
- For House Service Connection
- Anti-intrusion Barrier
- Rated Voltage AC 500V



Front and Back Wire Models

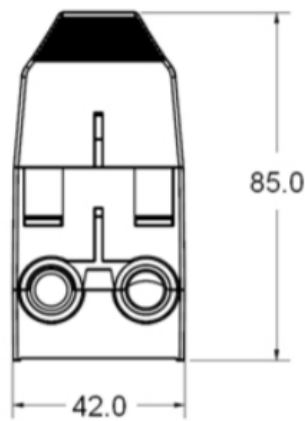
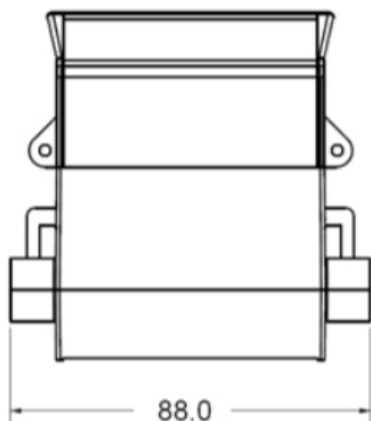

Back Wire Drilling

